

Towards development of a standard methodology for testing field performance of residential greywater reuse systems: case study of a greywater reuse system installed in 22 homes in Southern Ontario (Canada)

Madeleine Craig and Russell Richman

ABSTRACT

Using shower wastewater to flush toilets decreases the potable water demand of residential buildings, reducing pressure on existing water supplies. 'Off-the-shelf' greywater reuse systems intended for single-family residential dwellings have recently become commercially available, but have variable field performance. A standard field testing methodology was developed and applied to a greywater reuse system installed in 22 homes in Southern Ontario. Performance was quantified by measuring the water balance, water quality, energy consumption, durability, maintenance requirements, installation process, economics and user satisfaction with the system. The tested system was found to save, on average, 40.9 litres per household per day, occasionally meet water quality guidelines and generally have less maintenance and durability issues than previous generations, resulting in satisfied users. However, due to low water rates and high capital costs, there is a need for government subsidization of these systems which will ultimately reduce pressure placed on centralized water infrastructure.

Key words | decentralized water treatment, greywater, greywater treatment, non-potable reuse, water conservation, water reuse

Madeleine Craig
Russell Richman (corresponding author)
Ryerson University,
350 Victoria Street, Toronto,
Canada
E-mail: richman@ryerson.ca

INTRODUCTION

Due to the unpredictable weather patterns, more frequent extreme weather events and drought associated with climate change, current water sources are becoming less reliable (International Water Management Institute 2014). Relative to other Organisation for Economic Cooperation and Development (OECD) countries, Canada ranks fourth in highest water abstractions per capita with an annual consumption of 1,025 cubic metres per person per year. At this abstraction rate, the national annual volume totals approximately 35 billion cubic metres per year (OECD 2016).

This is an Open Access article distributed under the terms of the Creative Commons Attribution Licence (CC BY 4.0), which permits copying, adaptation and redistribution, provided the original work is properly cited (<http://creativecommons.org/licenses/by/4.0/>).

doi: 10.2166/wrd.2017.020

In order to support future water demands, additional water supplies can be obtained through intensive and costly processes such as deep groundwater abstraction, desalination or importing water from far distances (Environment Agency 2012). Water conservation is a more reasonable and less impactful method to secure water sources that can be achieved through optimizing existing water infrastructure, demand-side water conservation technologies such as high-efficiency toilets, changing behaviour and decentralized water reuse systems (Inman & Jeffrey 2006; DeOreo *et al.* 2016).

Water reuse provides an alternate water supply to reduce the pressure on our jeopardized traditional freshwater sources (Daigger 2009; International Water Management

Institute 2014). The concept of 'fit for purpose' is encouraged, which is the principle that alternative water sources should only be treated to the required water quality level needed for the desired end use. Higher water quality requires increasing levels of treatment, which have higher associated energy and cost requirements (US EPA 2012). A decentralized system could consume an equal or lesser amount of energy than that required for treatment and pumping water from a centralized system; however, this value is site specific (Daigger 2009). In residential buildings, alternative water sources available for capture, treatment and reuse range from relatively high quality sources such as rainwater (depending on location) to sources that require more treatment prior to reuse including shower wastewater (greywater) and toilet wastewater (blackwater). The 2016 *Residential End Uses of Water* study update showed that water consumed in a home for toilet flushing has decreased 29% since 1999, but is still the greatest potable water consumer in a home (32.6 gphd or 123.4 lphd). In addition, there has not been any improvements in shower water consumption, with the average shower time lengths and flow rates remaining similar to those of 1999 (the average household consumes 26.9 gphd or 101.8 lphd for showering) (DeOreo *et al.* 2016).

This balance in potable water consumption and non-potable water production (showers, baths, sinks, laundry) within residential buildings lends itself well to greywater reuse (Jefferson *et al.* 2004; Hodgson 2012; Sharvelle *et al.* 2013). Typical examples of greywater reuse applications include toilet flushing, irrigation and, in some cases, laundry (Pidou *et al.* 2007). Through reconfiguration of plumbing and the possible addition of onsite treatment, greywater can be a significant source of water for activities in the home that do not require potable water (Gross 2008).

Greywater treatment systems are available worldwide, employing different methods of treatment resulting in varying levels of system complexity and cost. One of the least expensive and easily constructed and maintained designs is a combination of physical and chemical treatment, labelled 'simple treatment systems'. These simple systems comprise: two treatment stages (coarse filtration and/or sedimentation to remove large particles, and disinfection), a way to divert the greywater from the sewer (dual plumbing), a storage tank and a pump to distribute treated greywater to the end use (Christova-Boal 1995; Pidou *et al.* 2007).

These simple treatment systems have recently become commercially available for the residential market and have been designed to contain all water treatment components for greywater reuse. The systems can be installed into a single family home's mechanical room where the house has been equipped with dual-plumbing.

However, previous studies have found that the first generation of these 'off the shelf' greywater reuse systems had poor performance and implementation issues, and that further evaluation of available greywater reuse systems is required (De Luca 2012). There is a lack of knowledge surrounding the performance of these systems, in terms of long-term reliability, costs, and how they interact with centralized distribution systems (Moglia *et al.* 2011).

Until recently, much of greywater reuse research has focused solely on the treated greywater quality (Domenech & Sauri 2010; Sharvelle *et al.* 2013). Issues that have not been academically measured include frequent-to-excessive user involvement (maintenance), recurrent breakdowns (Domenech & Sauri 2010; Environment Agency 2011; De Luca 2012), odour, and effect on flushing mechanisms (Sharvelle *et al.* 2013). The cost of these systems varies and has been found to be 'largely uneconomical for a single family dwelling', due to low potable water prices and high installation costs (Li *et al.* 2009; De Luca 2012).

Much of the performance testing for single family residential greywater reuse systems is done in laboratories which do not capture the variability of in-situ greywater reuse system performance. Additionally, many of the studies have focused on greywater reuse for irrigation, rather than for applications within the home (Hodgson 2012).

More recently, packaged treatment system manufacturers have conducted pilot projects to evaluate the performance of their systems installed in residential buildings, without a standardized testing methodology for pilot studies. This research aims to develop a standard methodology to evaluate the performance of these 'off the shelf' systems in residential settings, showing accurate performance data for manufacturers, consumers and municipalities to compare systems with equivalent performance data. After developing the methodology, it was also then applied to a field study to show the efficacy of the testing methodology.

METHODS

In order to develop a standard testing methodology for assessing field performance of residential greywater reuse systems, a review of existing performance guidelines, regulations and standards, and previous field assessments was completed.

Multiple standards have been developed to test the performance of residential greywater reuse systems. These standards require the system to be set up in a laboratory setting and be dosed with simulated greywater over a typical period of six months. Parameters such as construction, operation and maintenance, and effluent water quality are assessed.

The two most relevant standards for this research are *NSF/ANSI Standard 350: On-site residential and commercial water treatment systems* and *CSA Standard B128.3-12 Performance of non-potable water reuse systems*, which have similar methods to quantify performance. Methodology such as testing time frame, typical maintenance and durability testing (power outage) were drawn from these standards for this work (NSF International 2011; Canadian Standards Association 2012).

Through literature review, it became apparent that there are several key metrics that best quantify field performance and should be included in a standard testing methodology (see Table 1).

Following the work done by De Luca (2012) and CSA Standard B128.3-12 most comprehensively, field performance of greywater reuse system treatment should be quantified through measuring water savings, water quality, energy use, durability, maintenance requirements, installation process, economics and user satisfaction.

PROPOSED FIELD TESTING PROTOCOL

It is proposed that the following field testing methodology be applied, in conjunction with CSA B128 laboratory testing standards, to any new simple system on the market, as it clearly shows how the system performs in an unpredictable field setting. The methodology is intended for the manufacturer to carry out a pilot study prior to releasing the system to the general market.

The standardized results from the pilot study are beneficial to: (i) future system buyers who should be aware of the savings and operation requirements for the system; (ii) the manufacturer and other water conservation industry members who can improve the technology moving forward; and (iii) municipalities who can provide promotions and incentives for their residents, if the performance results show that the system is an effective water saving option.

Development of user profiles (Survey #1)

Two electronic surveys should be conducted in order to quantify system performance. A preliminary survey should be conducted in order to record the 'base conditions' prior to installation of the greywater system as well as certain household conditions as performance of greywater reuse systems varies due to site specific characteristics (Christova-Boal 1995; De Luca 2012). Household characteristics that should be recorded include: (a) age of residents, (b) time spent in the house, (c) frequency of showering, (d) number of residents, (e) presence of water softener, (f) location of showers and toilets, (g) personal care products, (h) cleaning products, (i) frequency of cleaning, (j) toilet flush volume, (k) household pipe configuration and (l) number of storeys in the home.

Testing period

Shower greywater quality and production have not been found to vary seasonally; therefore, testing for only a portion of the year can be representative of system performance throughout the year (De Luca 2012; Vandegrift 2014). Following laboratory standard testing methods, it is suggested that at least six grab samples be collected for water quality testing, and that at least six months of water balance and energy consumption data be collected.

Frequency of required maintenance has decreased since previous system generations and it is therefore suggested that maintenance be tracked for at least one year to fully show annual maintenance requirements.

Table 1 | Summary of field performance metrics of residential greywater reuse systems in previous literature

Metrics used to assess greywater reuse system feasibility and performance	Christova-Boal (1995)	Surendran (2001)	Al-Jayyousi (2003)	Noide (2005)	Morel & Diener (2006)	Friedler & Hadari (2006)	Mandal et al. (2011)	Mourad et al. (2011)	Bergdolt (2011)	Hodgson (2012)	Sphar (2012)	De Luca (2012)	Sharville et al. (2013)	Vandegriff (2014)	CSA B128.3-12 (2012)
Public health (water quality)	●	●	●	●	●	●	●		●	●		●	●	●	●
Economic feasibility	●	●		●		●	●	●	●	●	●	●	●	●	
Water balance (water savings)	●	●					●	●	●		●	●	●	●	
Social/User acceptance	●	●	●	●	●						●	●		●	
Technical feasibility	●		●						●		●	●	●	●	
Impact on the environment	●		●		●							●			
Maintenance									●	●		●	●		
Regulation compliance					●				●		●	●	●		
Water aesthetics				●								●	●		
Energy use										●		●			
System design															●
System noise															●
Power failure															●
Vacation mode															●
'Work-week' testing															●
Peak flow testing															●

Water balance

Previous studies have equipped the greywater reuse systems under observation with flow meters on the influent and effluent pipes to establish greywater collection and use (Christova-Boal 1995; De Luca 2012). These volumes can be validated by asking the system users to fill out log sheets tracking their water production and consumption activities (Christova-Boal 1995).

In order to show the water saving capabilities of the system, it is important to show any reliance of the system on external water sources (utility/municipal supplied water), as well as any wasted greywater. Therefore, the water savings metric should be recorded through a water balance analysis.

Figure 1 highlights five key volumes that must be documented when recording water savings and quantifying the water balance, a principle which states that the sum of Volumes 1 and 2 (water in) should equate to Volumes 3, 4 and 5 (water out).

If possible, meters can be placed on each line in and out of the treatment system to show greywater production and consumption from each fixture. However, not all associated volumes should be metered due to debris and particulates that could clog the rotating parts in the flow meters. Thus, a water balance approach is proposed as a method to estimate key volumes that cannot be metered (De Luca 2012).

Using a data logging program which records each event and time of event is a more thorough data collection method than flow meters which only provide an overall volume over the time period between meter readouts. Recording each event can show daily habits which can help optimize the greywater reuse process. Having users record each event manually through a log sheet can also be effective but relies on users for accuracy.

Once each volume is metered, the best way to evaluate water savings performance of a system is to compare greywater production to the volume of water (treated greywater or supplementary potable water) used for the non-potable end use. These metrics should be documented in litres per household per day (lphd), and litres per capita per day (lpcd). In the situation where the system is equipped to empty the storage tank after a certain time period, for water quality purposes, water savings should be evaluated over that time period. These measurements can then be used to determine trends in greywater consumption and production based on household characteristics (e.g., all residents are out of the house on weekdays during the day) as well as compare the results to the performance of other water conservation technologies (e.g., dual-flush toilets).

Water quality

Protection of public health must be considered when reusing greywater. Water quality of raw greywater from

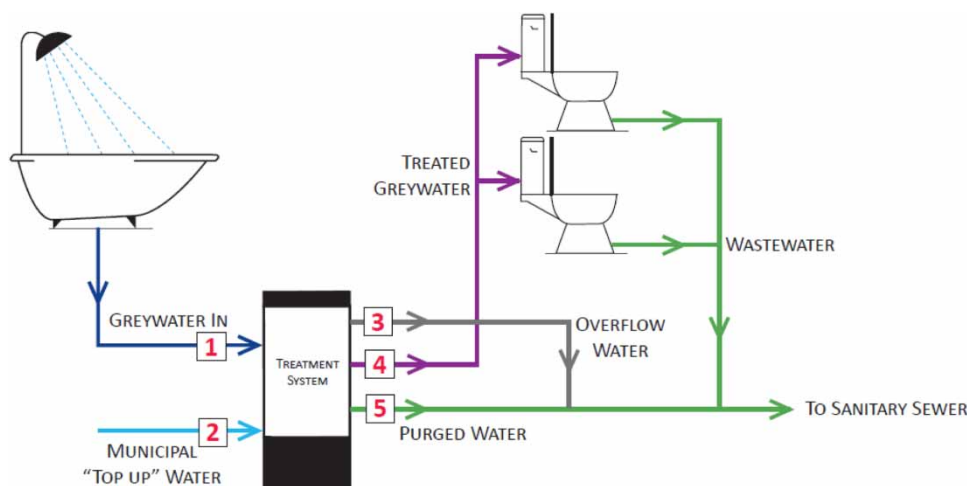

Figure 1 | Residential greywater reuse process with five key volumes to the water balance analysis labelled.

residential sources is well researched and has been found to be comparable to raw wastewater, thus treatment is required prior to reuse (Dixon 1999; Health Canada 2010). In order to present the performance of the treatment by a greywater reuse system, the water quality of the influent and effluent water should be sampled to verify whether treatment is sufficient to meet applicable regulations (Morel & Diener 2006; Vandegrift 2014). Table 2 summarizes what has been measured through both regulations and prior studies.

Following the work done by De Luca (2012) and Health Canada's guidelines for greywater reuse most extensively, treatment assessments should measure: biochemical oxygen demand (BOD₅), chemical oxygen demand (COD),

total and faecal coliforms, free and total chlorine residual, turbidity, colour, hardness, odour, pH and temperature.

Sampling locations

Ideally, in order to show performance of the greywater reuse treatment system, grab samples would be taken immediately prior to and after treatment. However, due to typical plumbing configurations and logistical restrictions that arise when working directly with homeowners, the following methodology is proposed.

Raw shower greywater. As close to scheduled testing visits as possible, each user should be instructed to plug

Table 2 | Water quality parameters evaluated in guidelines and previous work on greywater reuse

Parameter	Guidelines			Previous work		
	Health Canada Guidelines (2010)	US EPA Guidelines for Water Reuse (2012)	CSA B128.3-12 (2012)	Eriksson et al. (2002)	Hodgson (2012)	De Luca (2012)
BOD ₅	●	●	●	●	●	●
Turbidity	●	●	●	●	●	●
Total suspended solids (TSS)	●	●	●	●	●	
Total chlorine residual	●	●	●		●	●
COD			●	●	●	●
Thermotolerant coliforms	●	●	●			●
pH		●	●	●	●	
<i>E. coli</i>	●		●		●	
Temperature			●	●	●	
TOC			●	●		
Conductivity				●	●	
Ammonia (NH ₃)			●	●		
cBOD ₅			●			
TDS					●	
Total solids (TS)					●	
Colour			●			
Odour			●			
Total coliforms					●	
Total Kjeldahl nitrogen (TKN)			●			
Total nitrogen (TN)				●		
Total phosphorus (TP)			●			
Alkalinity				●		
Oily film and foam			●			
Dissolved oxygen					●	
DCOD					●	

the tub of their shower at the beginning of their shower, and collect a water sample of at least 1 litre. Ideally, a homogenous mix from the entire shower period should be collected for each user (which would account for all personal care products used during the shower), but this is not a reasonable request. Samples should be collected from the bathwater of all residents in the home. Raw shower greywater should be stored in the refrigerator until tests can be made or it can be transported in a cooler to a laboratory for testing.

Treated greywater. Treated greywater should be sampled from an outlet valve from the pipe that pumps greywater to the toilets throughout the house. If that is not possible, grab samples should be taken from the storage tank, post treatment. To correlate any water quality degradation of the treated greywater during storage, the length of time that the treated greywater has been stored in the tank should be recorded at the time of sampling. A representative elapsed storage time of the treated greywater can be determined by estimating the per cent breakdown of the water in the storage tank by comparing volumes in and out of the storage tank to the event times.

Treated greywater in toilet tank. Samples of treated greywater should be taken from the toilet tank, rather than the toilet bowl, as additional bacteria can be added to the greywater once it fills the toilet bowl. If time and funds allow, water quality samples should be taken from all toilets within the home; however, one toilet tank can represent the performance of the system at each house. Testing should always be completed at the same toilet tank in the house. It would be beneficial to have a timer on the toilets to indicate time since the last flush, indicating age of the water in the toilet tank.

Municipal water. Municipal water samples can be collected from any faucet in the house in order to show base water quality. It is recommended that the faucet be allowed to run for 1 minute as it is possible for chlorine to build up in the distribution lines if the faucets have not been used recently.

Testing parameters

Standard Methods for the Examination of Water and Wastewater should be followed to collect and test water quality

parameters (Rice *et al.* 2012). Odour at each of the four testing locations should be recorded as either: no odour, chlorine, greywater or soap.

Periods of inactivity

Through the user survey, users should be asked to indicate any planned vacations, in order to correlate system water quality, water savings, energy and durability data to these dates. Water quality samples should be taken at all locations just prior to leaving for the extended time period and again as soon as the users return home, specifically noting water quality at the toilet tanks.

Energy use

Treating and reusing greywater at a single family residential scale can use more energy and be more carbon intensive than municipal water treatment (Environment Agency 2011; De Luca 2012). Therefore, it is imperative to document energy use of residential greywater reuse systems and compare it to energy used to provide municipally supplied potable water to residential buildings.

Energy intensity of the system should be recorded, which is defined as the energy (kWh) required to extract, treat and distribute 1 cubic metre of water. Energy intensity (kWh/m³) puts energy use of the system into a term comparable with other methods of treatment, such as local centralized treatment plants (Mass 2009; De Luca 2012).

Energy use can be measured using plug-in electricity meters, which intercept the greywater reuse system plug and the outlet, tracking a rolling log of energy use, or over short periods of time. At the end of the study period, energy intensity values can be calculated by comparing the volume of reused water to system energy consumption.

Durability

Through previous work and anecdotal experience, it has been shown that system and equipment failures are frequent and should be documented. De Luca (2012) found that all homes experienced some difficulty with their systems, with the most common issues being mechanical failures as well as a film building up in the toilet storage tank (De Luca

2012). It was also found that many failures involved the toilets specifically, indicating that perhaps greywater reuse systems do not operate well with certain fixtures (De Luca 2012). These failures should be quantified through the performance metric 'durability'.

Durability should be assessed in two ways. First, the tester should record any noticeable failures at each test visit, through observation and discussion with the system user, if possible. Filter and toilet flush valve clogging is an aspect of durability that should be heavily monitored. A method such as tracking water flowing through the filter or pressure loss across the filter should be incorporated into testing in order to track filter clogging. However, visual inspection of the filter at each visit could sufficiently show build up and clogging.

Another issue that should be taken into consideration and monitored by the tester at each visit is pressure loss throughout the system. This can be monitored by tracking the time it takes to fill the toilet tanks after full and half-flushes at each site, over the period of the study. If possible, these times can be compared to toilets in the house that function with municipally supplied water to show how the system performs relative to traditional water sources. Other potential system failures include corrosion of metallic parts, water leakage/flooding and user interface (screen) errors.

Second, users' input on durability should be collected. A printed log sheet should be given to the system users to record each time an irregular system event occurs. It is recommended that the log sheet be attached to the greywater reuse system so users are visually reminded to fill in the details, if an issue were to arise. Users' input on durability should also be collected through the second user survey.

Maintenance

Routine maintenance of a system is required and, when properly completed, allows for optimal system performance. After installation, frequency and type of maintenance requirements might differ from a laboratory testing situation.

Maintenance frequency and level of user involvement varies based on the size of the system, the design and the type of treatment. Typical maintenance for current simple

greywater reuse systems includes filter cleaning and chemical additions (chlorine pucks).

Through user documentation during the field testing process and user surveys after the testing period, an assessment of maintenance requirements can be made. Maintenance logs should be kept for at least one year, to fully document annual maintenance requirements, including tasks such as annual backflow prevention testing. It is suggested that in order to grasp a full and accurate representation of required maintenance, log sheets be attached to the greywater reuse system and at every toilet.

Installation

The installation process varies depending on whether the building is new build (where the dual-plumbing and greywater reuse system can easily be incorporated during design) or the system is being incorporated into an existing structure (Bergdolt 2011; Vandegrift 2014).

The installation process of the system can be documented in terms of the cost of the installation and ease of system implementation.

The cost of installation can be evaluated by using invoices from the plumbers and general contractors (if applicable) during the installation process. The following points should be recorded at each installation site as they can greatly affect the installation process and the related installation costs: (a) number of storeys in the home, (b) location of the greywater reuse system (e.g., unfinished basement), (c) previously roughed-in or retrofit situation and (d) number and location of showers and toilets connected to the system.

Ease of system implementation can be documented through recording the user's satisfaction with the system installation process through the second survey as well as by interviewing the plumbers responsible for installing the system to find any common issues with the installation process.

Economics

In order to assess whether greywater reuse is a sensible water conservation option, the costs and benefits of the greywater reuse system need to be established (Friedler & Hadari 2006; Hodgson 2012; Vandegrift 2014). System costs

should be evaluated and compared to the life-span of the treatment system, in order to determine whether the system reaches economic efficiency (payback period is within the expected life-span of the system).

In order to provide an economic assessment of the greywater reuse system, the following details must be recorded: total capital cost, annual maintenance cost (disinfectant, filters, backflow prevention testing), annual operations cost (energy usage), water savings (i.e., water and wastewater savings).

As system performance varies at different sites, it is recommended that the method of economic analysis suggested by De Luca (2012) be followed and that three performance scenarios be evaluated: (i) best case: highest water savings with lowest costs (capital and annual), (ii) average case: average water savings with average costs and (iii) worst case: lowest found water savings with highest costs.

If the system is being evaluated using current Canadian water rates, it is expected that the payback period will not be within the expected life of the system. Therefore, an estimate should be made to calculate the required water rate or government subsidy that would have to be implemented in order for the system to reach economic efficiency.

Finally, a financial comparison between greywater reuse and other water conservation technologies should be made.

Evaluating the simple payback of the system is an effective method to show the financial reality of greywater reuse, but is a very rudimentary method of economic analysis. This method does not take into account inflation but accounts for an estimated 5% annual water rate increase, per the combined water and wastewater rates projected until 2022 by 14 municipalities in Southern Ontario. The method does not capture any additional environmental externalities such as reducing freshwater consumption. The developed methodology for economic analysis could be expanded by further presenting how the system economics change in more varied scenarios using statistical methods such as beta distribution.

User satisfaction and responses (Survey #2)

At the end of the field study, a second survey should be distributed to the system users to capture user satisfaction as well as performance data from the user's point of view.

General drawbacks stated by users of previous greywater reuse systems include unpleasant odours, poor water aesthetics, high maintenance costs and required maintenance/repairs (Domenech & Sauri 2010). The survey should first collect the user's 'environmental awareness' to benchmark the user's understanding of the system and water reuse in general, then proceed to collect user satisfaction with maintenance requirements, technical performance, economics and overall satisfaction.

Environmental awareness can be quantified by asking about other methods of water conservation practised in the home, why they have a greywater reuse system in the home and how much waste produced in the home is recycled. Through these questions, a general sense of the user's environmental commitment can be made and taken into account when assessing satisfaction responses.

Questions pertaining to maintenance should ask about the three most important aspects of simple greywater reuse system maintenance: toilets, disinfection products and the filter. The survey should aim to determine the extent of maintenance required for the system, whether the users were satisfied with the amount of effort they had to input (or were even capable of it) and, most importantly, how had their cleaning habits changed compared to when their toilets operated with municipal water.

The section of the survey dedicated to technical performance should aim to determine system durability and issues, and each user's acceptance of any technical difficulties. The system users should be able to indicate any technical issues or difficulties they experienced with the greywater reuse system from a list of frequent issues in 'off the shelf' greywater reuse systems or in a space for their own response. Users should also be asked about their satisfaction with the features of the system such as 'vacation mode' or any other special features.

The survey should ask about performance of 'state of the art' technology, covering system components such as control panels. For some, this could have been beneficial and added value to the system, while others could have believed it to be unnecessary and a source of frustration.

The economics portion of the survey should ask questions to determine how realistic the user believed the cost of this system and greywater reuse is. The user should be asked how likely they were to pay the capital and annual

expenses. If the user responds 'not at all likely', the user should be asked if including a government incentive would increase the likelihood of installing the system. Users should be asked what an acceptable payback period would be for them to consider installing the system, which can then be compared to the estimated payback period of the system.

The final portion of the survey should ask about the overall satisfaction of the system and, most importantly, would the users continue to use the system in their home.

Field study results

The developed standard testing methodology was applied to pilot test the performance of a commercially available, packaged, 'off the shelf' greywater reuse system for single family homes. The tested system can be installed to treat greywater from any source in the home, and be reused for any end use, but it is advertised as a system to treat shower wastewater (light greywater) to be reused for toilet flushing. The system is a second generation of greywater reuse systems, and has addressed common failures in previous systems as it features a self-cleaning filter, automatic tank emptying every 48 hours ('purge setting'), and a user interface which allows the user to control the level of chlorination.

The system was installed and evaluated at 22 single family homes in Southern Ontario (13 homes in the Guelph area, eight in the Barrie area and one in Toronto). Testing was completed from August 2014 to February 2015. Samples and data were collected through seven test visits. The purge setting was removed from six homes for the last two weeks and seven homes for the last week.

Water balance

The greywater reuse systems were equipped with a program which tracked volume and time of water coming in and out of the system, utilizing a pressure transducer at the base of the treated greywater storage tank. Volumes 1, 2, 4 and 5, as labelled in Figure 1, were tracked using the program. Any water that overflowed the storage tank was not able to be tracked (Volume 3 in Figure 1). One system was also equipped with flow meters in order to validate the accuracy of the pressure transducer and program. Additional validation tests were performed by releasing a known volume

of water into the system and observing recorded data. It was found that the flow meter values were recording volumes between 1 and 38% greater than the program, indicating that the program volume readings were potentially underestimated.

Water savings and water quality varied largely between each home in the field study, with some household characteristics directly influencing the performance, such as the number of residents at home during the day. However, occupant behaviour could potentially affect the performance of the system and should be further documented in future research. Table 3 shows a summary of the key volumes found in this field study, as daily averages.

It was found that the number of showers per resident per day (0.5 times per day with a volume of 22.9 L to 56.1 L) did not vary each month. Similarly, average toilet flushing values did not vary seasonally and therefore greywater consumption for toilet flushing can be considered a consistent draw on greywater sources. In this study, the average flush volume for the toilets was 5.52 L. The results support previous research that residential greywater reuse is a consistent supply and demand, year round.

Figure 2 shows the balance between greywater produced daily from showers and water (both greywater and municipal 'top up' water) consumed through toilet flushing at each of the field study houses. It can be seen that House 13 had the highest 'overconsumption' volume, which was expected as House 13 had additional employees working out of the house during the day flushing the toilet, but not providing shower greywater. House 13 was also found to have a leaking toilet for part of the study. House 1 (nine residents) had the most balanced greywater production to consumption volumes, only consuming, on average, 1.4 L

Table 3 | Summary of daily average key volumes, at the household and per capita level

Volume	With purge		No purge	
	L/HH/day	L/capita/day	L/HH/day	L/capita/day
Greywater in	65.8	18.8	–	–
Municipal 'top up' water	31.7	9.7	13.5	3.7
Water used to flush toilets	72.3	21.3	–	–
Water purged/emptied	32.6	8.9	12.2	1.9
Overflowed	–	–	–	–

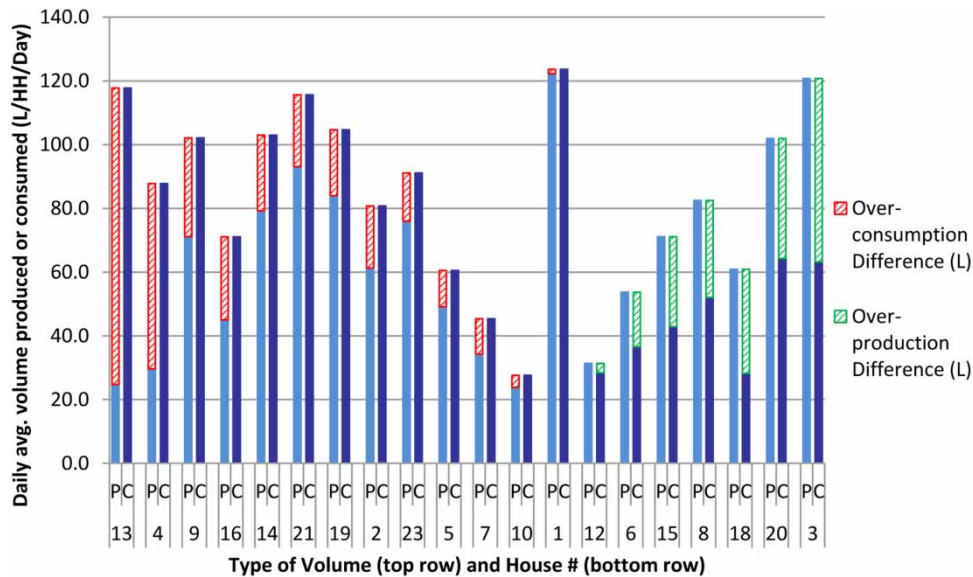

Figure 2 | Comparison between greywater production volumes ('P') and greywater consumption volumes ('C') at each house in the field study.

more greywater to flush than their house was producing through showering. House 3 (four residents), was hypothesized to be a high greywater producer and low consumer through the first survey, and was found to have the greatest greywater over-production volume.

On average, the systems required 44.3% of the flush water to be provided by municipal water, as the systems were refilled with municipal water immediately after a system purge. This was greatly reduced to 21.0% when the systems operated without the purge function (two-week period). These average results were comparable to De Luca (2012)'s study which required between 4.24 and 26.7% of flush water be provided by municipal water. The study results did vary largely between homes, confirming the need to review household characteristics when assessing water savings (e.g., number of residents).

Average daily water savings (total water used to flush toilets less any potable water added in order to flush the toilets) was 40.9 lphd, ranging from 10.3 to 96.9 lphd, depending on household characteristics (e.g., number of residents), as shown in Figure 3. When the system operated without the purge setting, the daily average water savings per household was 54.0 L. Daily household water savings were compared to the number of residents and suggested that greater daily water savings may be correlated to an increase in the number of residents. Further study into this

correlation is suggested by calculating a unit savings volume (litres per person per day).

Figure 3 shows how daily average water savings for the system ranged from 10.3 lphd to 90.8 lphd.

Water quality

Water quality was sampled and tested at four locations throughout the system's treatment train to show performance including: (i) base municipal water quality, (ii) raw shower water (untreated greywater), (iii) treated greywater in the storage tank, and (iv) stored treated greywater in the toilet tank. Samples for BOD₅, COD, total coliforms and faecal coliforms were transported to a laboratory for testing from seven homes, while free and total chlorine, turbidity, colour, hardness, odour, pH and temperature were taken *in situ* at 19 homes. Seven rounds of water quality samples were taken, including when the system was operating without the purge function. Additional research is suggested into the water quality degradation of stored treated greywater over time.

Five of the seven houses had children present, and house occupancy ranged from two to nine, with an average occupancy of four for the houses tested. Further analysis is suggested into the effects occupancy and children have on water quality.

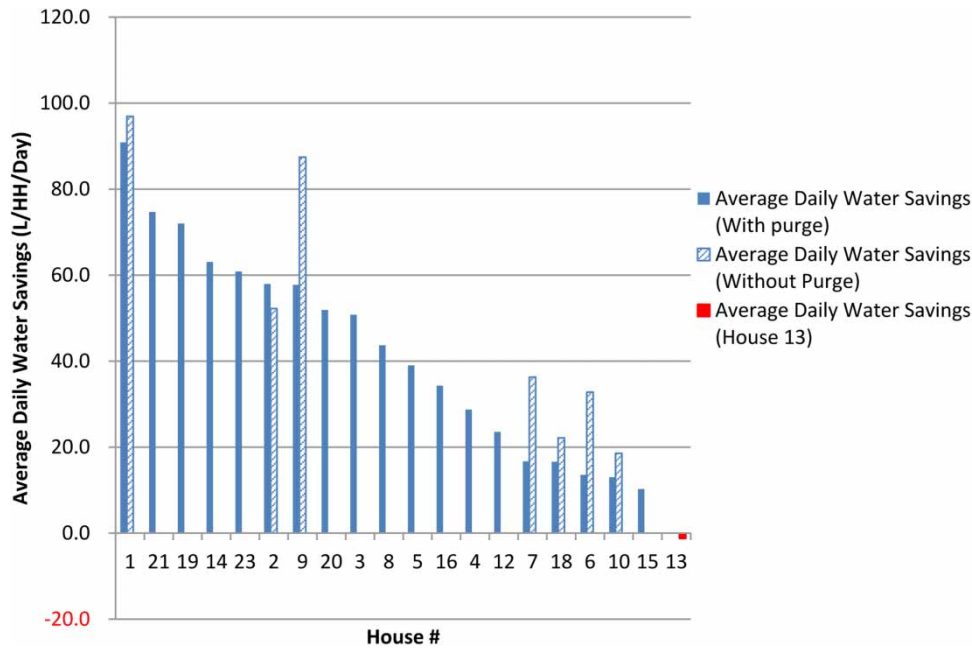

Figure 3 | Average daily water savings for each house in the field study.

Tables 4–6 provide a summary of the water quality parameters measured throughout the treatment train. Raw, untreated greywater samples were taken from user showers and presented in Table 4. Treated greywater samples were

taken from inside the system storage tank, after filtration and chlorination had occurred and from the toilet's water supply tank. Table 5 presents the values collected when the system was operating as the manufacturer had intended,

Table 4 | Summary of recorded water quality from collected shower samples

Parameter	Raw greywater				
	Unit	# of samples	Average	Max.	% that met HCG max
BOD ₅	(mg/L)	35	70 ^a	170	21%
COD	(mg/L)	35	112 ^b	250	–
Faecal coliforms	(CFU/100 mL)	34	23,746 ^c	>200,000	71%
Total coliforms	(CFU/100 mL)	35	28,678 ^c	>200,000	40%
Free chlorine	(mg/L)	80	0.13	0.69 ^d	–
Total chlorine	(mg/L)	79	0.18	0.98 ^d	8%
Turbidity	(NTU)	99	39.82	428.00	10%
Colour	(cu)	99	583	3,850	–
Odour	–	98	Soap ^e	–	–
pH	–	83	7.7	8.7	–
Temperature	(°C)	99	16.2	32.0	–

^aNon-detect values and >58 values were changed to 0 and 59, respectively, in order to calculate average.

^bNon-detect values were changed to 0 in order to calculate average.

^c<10 and >200,000 values were recorded as 9 and 200,001 respectively, in order to calculate average value.

^dIt is possible that soapy/sudsy water caused interference with measurement.

^e74% and 26% of samples had a soap odour and no odour, respectively.

Table 5 | Summary of recorded water quality at the greywater reuse system storage tank and at the toilet tank, with the purge setting

Parameter	Unit	Storage tank			Toilet tank		
		Average	Max.	% that met HCG max	Average	Max.	% that met HCG max
BOD ₅	(mg/L)	41 ^a	160	40%	40 ^a	140	31%
COD	(mg/L)	83 ^b	230	–	83 ^b	240	–
Faecal coliforms	(CFU/100 mL)	7,937 ^c	>200,000	93%	8,283 ^c	>200,000	86%
Total coliforms	(CFU/100 mL)	16,308 ^c	>200,000	75%	38,756 ^c	>200,000	54%
Free chlorine	(mg/L)	2.22	9.08	–	1.25	7.93	–
Total chlorine	(mg/L)	3.24	16.11	79%	2.17	13.03	65%
Turbidity	(NTU)	15.96	58.1	22%	14.62	80.50	19%
Colour	(cu)	273	923	–	267	974	–
Odour	–	Chlorine ^d	–	–	Chlorine ^e	–	–
pH	–	7.5	8.5	–	7.7	8.4	–
Temperature	(°C)	22.8	37.6	–	20.4	26.7	–

^aNon-detect values and >58 values were changed to 0 and 59, respectively, in order to calculate average.

^bNon-detect values were changed to 0 in order to calculate average.

^c<10 and >200,000 values were recorded as 9 and 200,001 respectively, in order to calculate average value.

^d60%, 27%, 24% and 1% of samples had a chlorine odour, no odour, greywater odour and soap odour, respectively.

^e48%, 27% and 24% of samples had a chlorine odour, no odour and a greywater odour, respectively.

with the purge function emptying the storage tank every 48 hours. Table 6 presents water quality when the system was operating without the purge function. Age of the treated greywater was not recorded and is suggested to be recorded

in future studies as it is possible treated greywater could have been sitting in the toilet tank for extended periods of time. Samples of municipal water were also taken as a base for comparison.

Table 6 | Summary of recorded water quality at the greywater reuse system storage tank and at the toilet tank, without the purge setting

Parameter	Unit	Storage tank			Toilet tank		
		Average	Max.	% that met HCG max	Average	Max.	% that met HCG max
BOD ₅	(mg/L)	38 ^a	100	50%	41 ^a	91	42%
COD	(mg/L)	88 ^b	250	–	96 ^b	170	–
Faecal coliforms	(CFU/100 mL)	438 ^c	4,400	82%	18,698 ^c	>200,000	82%
Total coliforms	(CFU/100 mL)	4,594 ^c	50,000	83%	51,138 ^c	>200,000	42%
Free chlorine	(mg/L)	2.13	5.13	–	1.45	5.81	–
Total chlorine	(mg/L)	3.10	7.91	92%	2.20	7.49	54%
Turbidity	(NTU)	10.88	24.60	23%	14.89	35.60	23%
Colour	(cu)	185	327	–	279	705	–
Odour	–	Chlorine ^d	–	–	Chlorine ^e	–	–
pH	–	7.9	8.3	–	7.8	8.1	–
Temperature	(°C)	19.2	29	–	18.0	21.1	–

^aNon-detect values and >58 values were changed to 0 and 59, respectively, in order to calculate average.

^bNon-detect values were changed to 0 in order to calculate average.

^c<10 and >200,000 values were recorded as 9 and 200,001 respectively, in order to calculate average value.

^d92% and 8% of samples had a chlorine and greywater odour, respectively.

^e46%, 31% and 23% of samples had a chlorine odour, greywater odour and no odour, respectively.

Results were averaged and compared to the Health Canada Guidelines, to show whether the treated water quality provided by this system met their standards. Water quality varied greatly at each home as well as throughout the greywater treatment process.

Raw greywater. BOD₅ levels ranged significantly in raw untreated greywater and rarely met the Health Canada greywater reuse guidelines of a maximum of 20 mg/L, supporting previous research indicating that raw residential greywater quality is variable and that treatment is necessary for reuse.

Treated greywater with and without system purge setting. On average, chlorine residual exceeded required chlorine levels. When adequate chlorine levels were present in the greywater storage tank, faecal coliforms regularly met required guidelines levels showing that periodical circulation of stored filtered residential greywater through chlorine tablets can provide adequate disinfection. Higher faecal coliforms levels were common at the toilet tank as available chlorine began to diminish. Although water quality measurements typically showed adequate treatment, eight of 17 users still experienced an unpleasant greywater odour in the bathrooms. Film buildup in the toilet tanks was also very common, thus confirming that treated greywater performs differently in toilets when compared to potable water.

Energy consumption

System energy use was measured using either the Belkin WeMo or the Kill-a-Watt meter. The studied system was found to consume, on average, 0.077 kWh/day. The energy intensity of the system ranged from 0.61 to 2.763 kWh/m³, with an average value of 1.346 kWh/m³. These results indicate that this system is less energy efficient than municipal treatment, supporting previous simple system greywater treatment research (De Luca 2012). However, through metering, the system was only recorded as operating for 15 minutes per day, with the remaining time spent on system standby. Seventy-three per cent of the system's energy use was consumed by operating on standby, and if this was reduced, the system would have a lower energy intensity than municipal systems. These findings further support the

need for research into residential greywater reuse at greater scales (i.e., multi-family and mixed use buildings).

Taking the average daily energy use of the systems and the average energy rate of \$0.095/kWh in Ontario, the average energy cost to operate the system for the entire life of the system (ten years) was found to be \$26.70 (Ontario Energy Board 2015).

Durability

The durability assessment of the system showed the most common failures were film buildup in the toilet tanks, which could lead to blocked flush valves and subsequent toilet leaking or toilet damage. Further research into the effects of greywater reuse on flush valves is recommended. The second most common failure, according to observation data, was unnecessary screen notifications (occurred at 74% of the houses). Fifty-seven per cent of the test houses showed signs of corrosion, specifically on the screws around the greywater tank lid. Many of these failures were repaired easily and were addressed during the testing period by the manufacturer. Some users also indicated through the user survey that the system was a noise nuisance as well as yielding unpleasant greywater or chlorine odours at the toilets.

The system's self-cleaning filter was found to be an improvement from previous system generations but still became clogged at some homes, requiring unexpected extra maintenance. Fifty per cent of homes experienced clogged filters and required maintenance more frequently than anticipated. The manufacturer indicated that filter maintenance would be required every six months, which was accurate for six of the system users (35%). However, five users (30%) found that the filter required maintenance every two to three months. Two users indicated that they did not yet have to clean the filter and two users were unsure as the frequent test visits interfered with regular maintenance. Correlations were not found between type of hygiene products used and filter issues; however, further research into this subject is suggested.

A thorough analysis of the system performance when the users were on vacation was not available, but the majority of the users who did go on vacation during the study indicated that they were very satisfied with the system performance while away. In the circumstance of a

power outage, the backup battery did not function and the system would not operate until power was turned back on.

Maintenance

Maintenance for the system was recorded using log sheets and through the conclusive user survey. For a house equipped with this greywater reuse system, the required maintenance included cleaning the toilet bowls once a week. Eighty-two per cent of users indicated they did not need to change the strength of cleaning product they used to clean their toilet bowls, which was typically regular strength toilet bowl cleaner. However, seven houses indicated using 'natural' cleaning products, vinegar and/or a toilet brush and were satisfied with maintenance.

Seventy-one per cent of users recorded some cleaning of the toilet tank was required as scum/mould could build up and affect the flush valves.

Through tests visits and user surveys, it was found that the majority of the systems (65%) had to refill their chlorine pucks every two to three months, meeting manufacturer specifications. Three houses indicated only having to replace their chlorine pucks every five to six months, but this is believed to be inaccurate as the chlorine pucks were replaced by the tester during test visits. Two other houses indicated they were unsure of chlorine refilling requirements as the test visits interrupted the schedule.

Fifty per cent of the users still found that they had filter issues, with two of the survey respondents indicating that they have to manually clean the filter once a month due to film buildup, blocking greywater from passing through. Five respondents noted having to clean the filter every two to three months, and six respondents indicated having to clean the filter every five to six months.

Overall, 16 of the 17 user respondents indicated that they were between 1 (Very satisfied) and 3 (Neutral) with all maintenance required for this greywater reuse, indicating that although some maintenance is required, users considered it to be reasonable.

Installation

Through review of the plumbing invoices, it became evident that a 'basic greywater reuse installation' required:

(i) roughing-in a drain from the showers and baths in the house to where the greywater reuse system would be located (such as the mechanical room); (ii) roughing-in a water supply line from the greywater reuse system to toilets; and (iii) installing and connecting the greywater reuse system. It is important to note how many storeys are in the home as extending the plumbing to bathrooms on higher floors can add to costs. 'Basic' installs were the least expensive, with an average installation cost of \$1,568.13 CAD for a single story bungalow. Once an additional storey was added, prices of installation increased to \$2,269.24 to \$2,912.26. The cost of repairs from installation (dry-wall repair, painting, etc.) ranged between \$1,025.00 and \$2,621.60. These repairs greatly increased the overall cost of installation and show the advantage of building homes to be reuse ready (dual plumbed), rather than retrofitting.

Ease of installation was documented through the second user survey; however, ideally, interviews with the installers would have also been conducted. Each home in this study had a mechanical room or a basement, and 14 of the 17 survey respondents indicated that they were very satisfied with the installation process.

Economics

Table 7 shows the results of the modelled best (high water savings, high rebates, low water rates), average and worst case (low water savings, low rebates, high water rates) economic scenarios.

The high capital and installation costs do not allow for a reasonable payback period as the average water savings combined with low water rates does not provide a strong return. It was found that the system could reach economic efficiency under the best case scenario assuming there was a \$1,236 incentive given to the homeowner. This supports De Luca (2012) conclusion that installation of a low flow toilet is a much more economic method of water conservation than single-family residential greywater reuse at this time. By reducing the capital costs of a greywater reuse system through subsidization or by increasing municipal water rates, onsite treatment and reuse of residential greywater from single family homes would become feasible.

Table 7 | Economic analysis of the studied greywater reuse system

	Best case	Average case	Worst case
Capital cost (\$)	\$1,499.00	\$2,000.00	\$2,499.00
Installation cost (\$)	\$862.44	\$1,677.71	\$4,638.39
Total immediate cost (\$)	\$2,361.44	\$3,677.71	\$7,137.39
Water savings (L/house/day)	96.906	26.045	10.265
Annual water savings (m ³)	35.371	9.506	3.747
2015 Combined water rate (\$/m ³)	\$4.44	\$3.15	\$2.03
Annual savings (\$)	\$157.05	\$29.95	\$7.61
Annual maintenance (\$)	\$8.04	\$52.69	\$194.23
Annual operation (\$)	\$1.55	\$2.68	\$6.30
Total annual costs (\$)	\$9.59	\$55.37	\$200.53
Payback period (years) (assuming 5% annual water rate increase)	11	43	52

User satisfaction

After completing site test visits, a second online survey was sent to the system users to gather information on their experience with the system and determine whether users enjoyed having the system in their home. Documented 'environmental awareness' was not incorporated in user satisfaction data analysis.

Although an exact comparison cannot be made, it appears that users are generally more satisfied with this greywater reuse system than previous generations, as 14 of the 17 survey respondents indicated a level 1 (Very satisfied) (47% of users) and 2 (Somewhat satisfied) (35% of users) for overall system performance. Twelve of the 17 respondents would continue to have the system in their home. One respondent, House 1 which was operating with nine residents, was overall, not satisfied with the system and indicated that major improvements to the system would be required in order to keep the system in their home.

CONCLUSIONS

By applying the standard testing methodology that was developed in the first part of this research to a case study, it was shown that the developed standard testing methodology and eight testing metrics can successfully grasp the

overall field performance of a single-family residential greywater reuse system. Overall, the developed methodology accurately captured the core greywater reuse system performance metrics of water savings, water quality and energy consumption, while also presenting the less tangible performance issues of the greywater reuse systems once they are installed in to a home, such as durability, maintenance requirements and user satisfaction.

It is proposed that the standard testing methodology be used by greywater reuse system manufacturers in conjunction with standard laboratory testing, such as *CSA B128* and *NSF 350*, to present a complete assessment of the system's performance under varying conditions.

Homeowners, municipalities and manufacturers will greatly benefit from the application of the developed testing methodology as it will allow for a clear and comparable field review of available greywater reuse systems.

Actual water savings and economic feasibility could be considered the most important metrics of assessment of this greywater reuse system, as few data have been presented previously on the true field performance of residential greywater reuse systems in Southern Ontario. On average, the homes in this study did produce roughly the same amount of water (65.8 Lhhd) as was consumed by flushing toilets (72.3 Lhhd), which shows that greywater is a sufficient water supply for toilet flushing in homes. Further, when the automatic purge setting was removed from the system, municipal water demand decreased.

At this point, greywater reuse in single family residential homes (Canada) does not make financial sense, unless it is subsidized. By reducing the capital costs of a greywater reuse system through subsidization, onsite treatment and reuse of greywater would become feasible. Decentralized treatment would reduce the pressure placed on deteriorating municipal infrastructure and would reduce the total amount of energy and chemical treatment required to municipal treated water and wastewater.

In summary, the methodology developed to test field performance of 'off the shelf', single family, residential greywater reuse systems successfully captured performance data when it was applied to a field study. The methodology can be applied to simple treatment systems (filtration, chlorination and sedimentation during storage of any particles that passed through initial filtration) but will require expansion as more complex systems are developed. It is proposed that the standard testing methodology be used by greywater reuse system manufacturers in conjunction with standard laboratory testing to present a complete assessment of the system's performance under varying conditions. Homeowners and municipalities will also greatly benefit from the application of the developed testing methodology as it will allow for a clear and comparable review of available systems.

REFERENCES

- Al-Jayyousi, O. R. 2003 [Greywater reuse: towards sustainable water management](#). *Desalination* **156**, 181–192.
- Bergdolt, J. H. 2011 *Graywater Reuse Guidance and Demonstration Using A Constructed Wetland Treatment System*. Colorado State University, Fort Collins, CO, USA.
- Canadian Standards Association 2012 *CSA B128.3-12 Performance of non-Potable Water Reuse Systems*. CSA Group, Mississauga, ON, Canada.
- Christova-Boal, D. 1995 *Installation and Evaluation of Domestic Greywater Reuse Systems*. Victoria University of Technology, Victoria, BC, Canada.
- Daigger, G. T. 2009 [Evolving urban water and residuals management paradigms: water reclamation and reuse, decentralization, and resource recovery](#). *Water Environment Research* **81** (8), 809–823.
- De Luca, M. 2012 *Appropriate Technology and Adoption of Water Conservation Practices: Case Study of Greywater Reuse in Guelph*. University of Guelph, Guelph, ON, Canada.
- DeOreo, W. B., Mayer, P., Dziegielewski, B. & Kiefer, J. 2016 *Residential End Uses of Water, Version 2: Executive Report*. Water Research Foundation, Denver, CO, USA.
- Dixon, A. M. 1999 Measurement and modelling of quality changes in stored untreated grey water. *Water* **1**, 293–306.
- Domenech, L. & Sauri, D. 2010 [Socio-technical transitions in water scarcity contexts: public acceptance of greywater reuse technologies in the Metropolitan Area of Barcelona](#). *Resources, Conservation and Recycling* **55**, 53–62.
- Environment Agency 2011 *Greywater for Domestic Users: an Information Guide*. Environment Agency, Bristol, UK.
- Environment Agency 2012 *The Case for Change – Current and Future Water Availability*. Environment Agency, Bristol, UK.
- Eriksson, E., Auffarth, K., Henze, M. & Ledin, A. 2002 [Characteristics of grey wastewater](#). *Urban Water* **4**, 85–104.
- Friedler, E. & Hadari, M. 2006 [Economic feasibility of on-site greywater reuse in multi-storey buildings](#). *Desalination* **190**, 221–234.
- Gross, A. W. 2008 [Reliability of small scale greywater treatment systems and the impact of its effluent on soil properties](#). *International Journal of Environmental Studies* **65** (1), 41–50.
- Health Canada 2010 *Canadian Guidelines for Domestic Reclaimed Water for Use in Toilet and Urinal Flushing*. Minister of Health, Ottawa, ON, Canada.
- Hodgson, B. 2012 *Development of A Cost Effective and Energy Efficient Treatment System for Graywater Reuse for Toilet Flushing at the Multi-Residential Scale*. Colorado State University, Fort Collins, CO, USA.
- Inman, D. & Jeffrey, P. 2006 [A review of residential water conservation tool performance and influences on implementation effectiveness](#). *Urban Water Journal* **3** (3), 127–143.
- International Water Management Institute 2014 *Strategy 2014–2018: Solutions for A Water-Secure World*. International Water Management Institute, Colombo, Sri Lanka.
- Jefferson, B., Palmer, A., Jeffrey, P., Stuetz, R. & Judd, S. 2004 [Greywater characterisation and its impact on the selection and operation of technologies for urban reuse](#). *Water Science and Technology* **50** (2), 157–164.
- Li, F., Wichmann, K. & Otterpohl, R. 2009 [Evaluation of appropriate technologies for grey water treatments and reuses](#). *Water Science and Technology* **59** (2), 249–260.
- Mandal, D., Labhasetwar, P., Dhone, S. & Dubey, A. S. 2011 [Water conservation due to greywater treatment and reuse in urban setting with specific context to developing countries](#). *Resources, Conservation and Recycling* **55**, 356–361.
- Mass, C. 2009 *Greenhouse Gas and Energy Co-Benefits of Water Conservation*. POLIS Project on Ecological Governance, Victoria, BC, Canada.
- Moglia, M., Cook, S., Sharma, A. K. & Burn, S. 2011 [Assessing decentralised water solutions: towards a framework for adaptive learning](#). *Water Resource Management* **25**, 217–238.
- Morel, A. & Diener, S. 2006 *Greywater Management in Low and Middle-Income Countries*. Swiss Federal Institute of

- Aquatic Science and Technology (Eawag), Dübendorf, Switzerland.
- Mourad, K. A., Berndtsson, J. C. & Berndtsson, R. 2011 [Potential fresh water saving using greywater in toilet flushing in Syria](#). *Journal of Environmental Management* **92**, 2447–2453.
- Nolde, E. 2005 Greywater recycling systems in Germany. Results, experiences and guidelines. *Water Science and Technology* **51** (10), 203–210.
- NSF International 2011 *NSF/ANSI 350 – 2011: Onsite Residential and Commercial Water Reuse Treatment Systems*. NSF International, Ann Arbor, MI, USA.
- OECD 2016 *OECD Factbook 2015–2016: Economic, Environmental and Social Statistics*. OECD Publishing, Paris, France.
- Ontario Energy Board 2015 *Electricity Prices*. (Ontario Energy Board) Retrieved April 30, 2015, from <http://www.ontarioenergyboard.ca/OEB/Consumers/Electricity/Electricity+Prices>.
- Pidou, M., Memon, F. A., Stephenson, T., Jefferson, B. & Jeffrey, P. 2007 [Greywater recycling: a review of treatment options and applications](#). *Engineering Sustainability* **160**, 119–131.
- Rice, E. W., Baird, R. B., Eaton, A. D. & Clesceri, L. S. 2012 *Standard Methods for the Examination of Water and Wastewater*. American Public Health Association, Washington, DC, USA.
- Sharvelle, S., Roesner, L. & Glenn, R. 2013 *Treatment, Public Health and Regulatory Issues Associated with Graywater Reuse: Guidance Document*. WateReuse Research Foundation, Alexandria, VA, USA.
- Sphar, K. M. 2012 *The Challenges to Implementing Decentralized Water Reuse: A Greywater Recirculation Case Study in Boulder, Colorado*. University of Colorado, Boulder, CO, USA.
- Surendran, S. S. 2001 *The Development of an In-House Greywater and Roof Water Reclamation System for Large Institutions, During 1994 to 1998*. Loughborough University, Loughborough.
- US EPA 2012 *2012 Guidelines for Water Reuse*. United States Environmental Protection Agency, Washington, DC, USA.
- Vandegrift, J. 2014 *Implementation of Graywater Reuse in the State of Colorado*. Colorado State University, Fort Collins, CO, USA.

First received 11 April 2017; accepted in revised form 20 July 2017. Available online 27 October 2017